



Woodcrest Bridge Project

DYLAN CLEMENTE

DEXTER EHRENZELLER

BRADLEY SLOOP

Thirteenth Annual School of Science, Engineering, and Health Symposium
April 28, 2017

Mission Statement

“To use our skills and abilities to impact the community around us in a way that shows God’s love”

Our Client

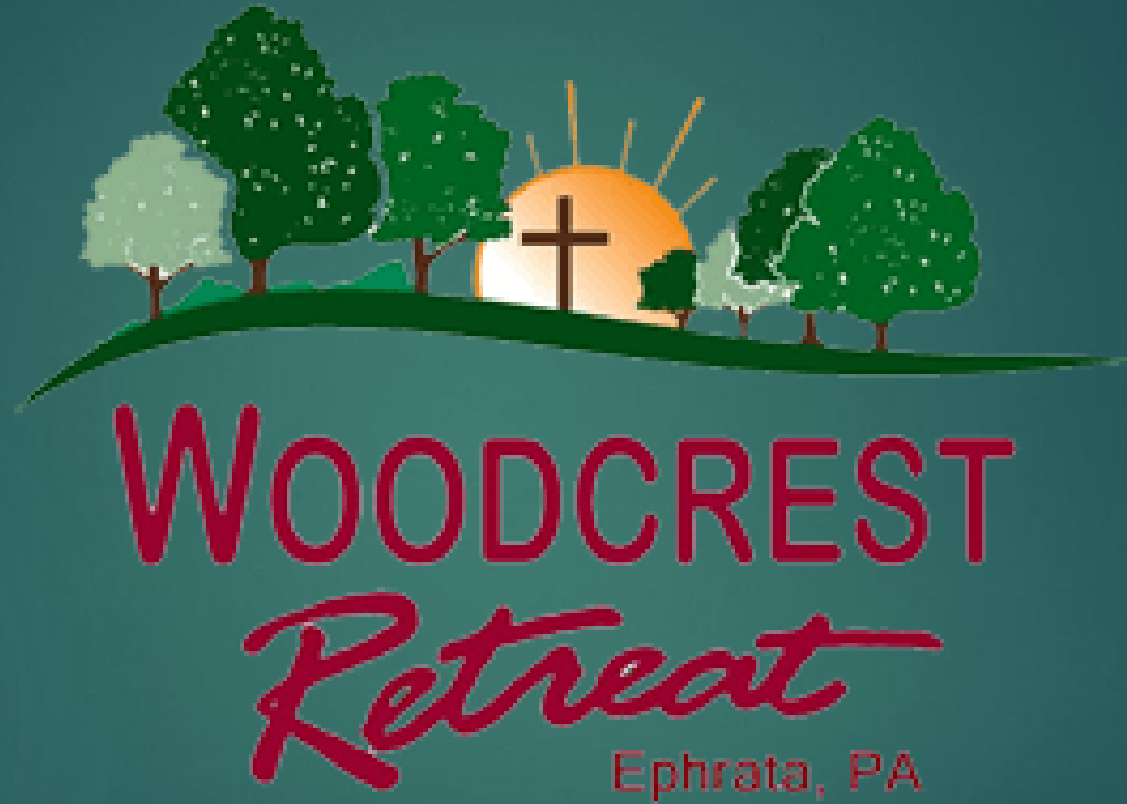

Cliff Martin, Executive Director

Client



WOODCREST
Retreat
Ephrata, PA

Engineering & Design

Construction



Larson Design Group®

The logo for Larson Design Group, featuring a stylized 'LDG' in a square followed by the text 'Larson Design Group®'.

the Collaboratory
for strategic partnerships
and applied research

The logo for 'the Collaboratory', featuring a stylized icon of three overlapping circles and the text 'the Collaboratory' with the tagline 'for strategic partnerships and applied research' below it.

HORST
CONSTRUCTION

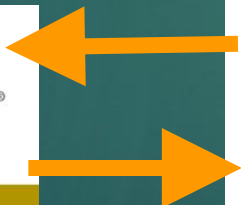
The logo for HORST CONSTRUCTION, featuring a stylized 'H' inside a hexagon followed by the text 'HORST CONSTRUCTION'.

Past Bridge History

- Panama Bridge team
 - Split into multiple teams



Project Need

- Need for a crossing over a rock swale to connect a hiking path
- Providing a ministry opportunity for Woodcrest Retreat
- Provide a point of interest for the camp

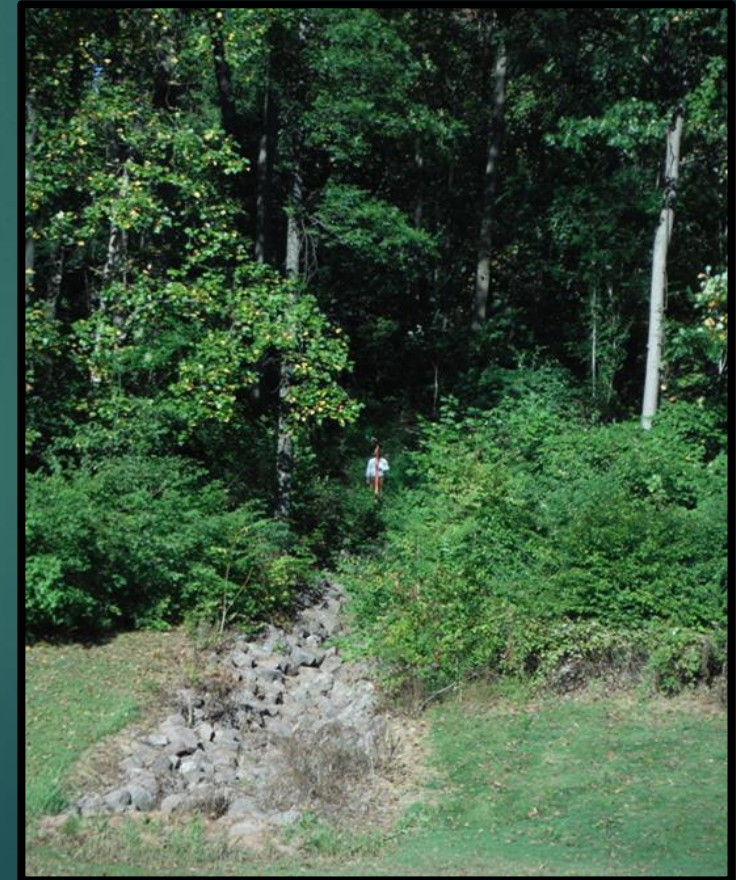
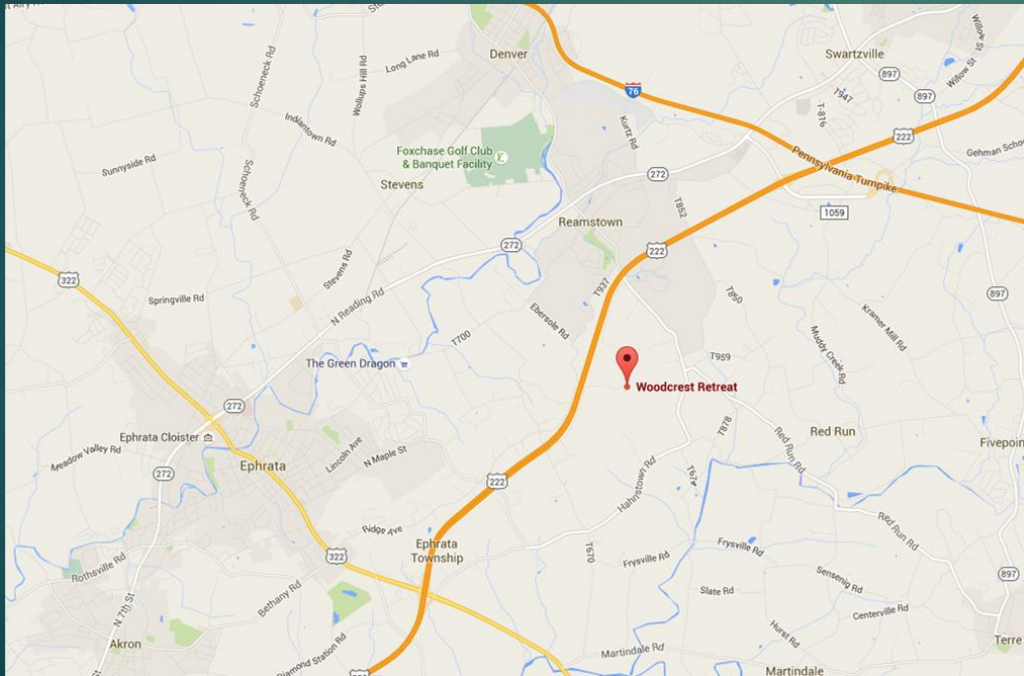

Solution: Bridge Type Selection

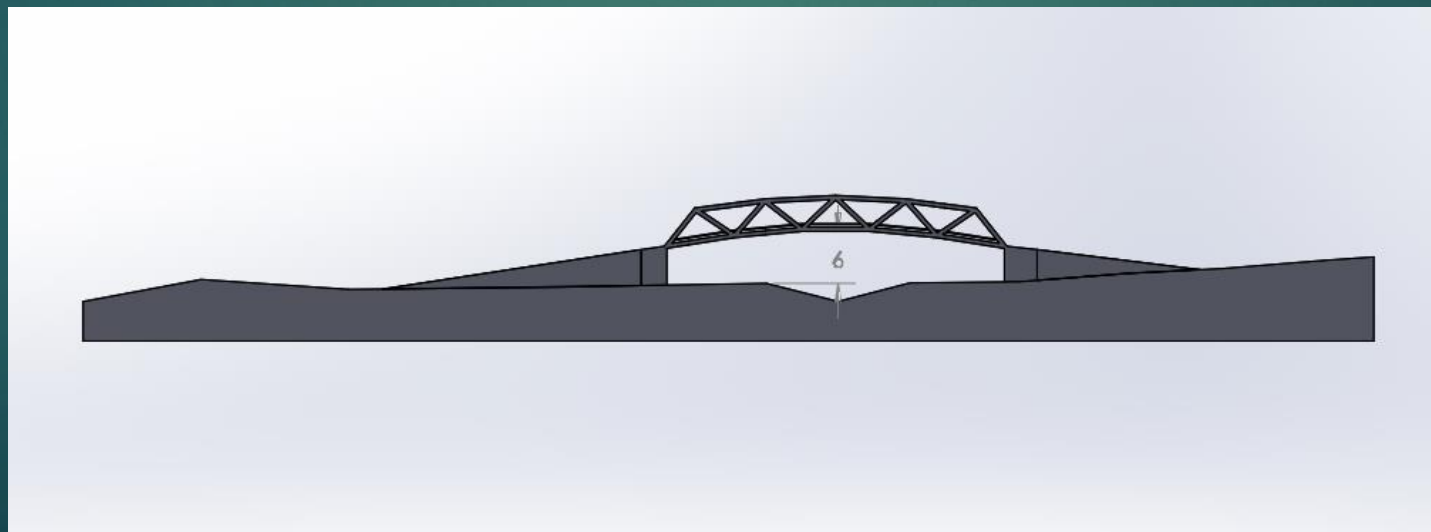
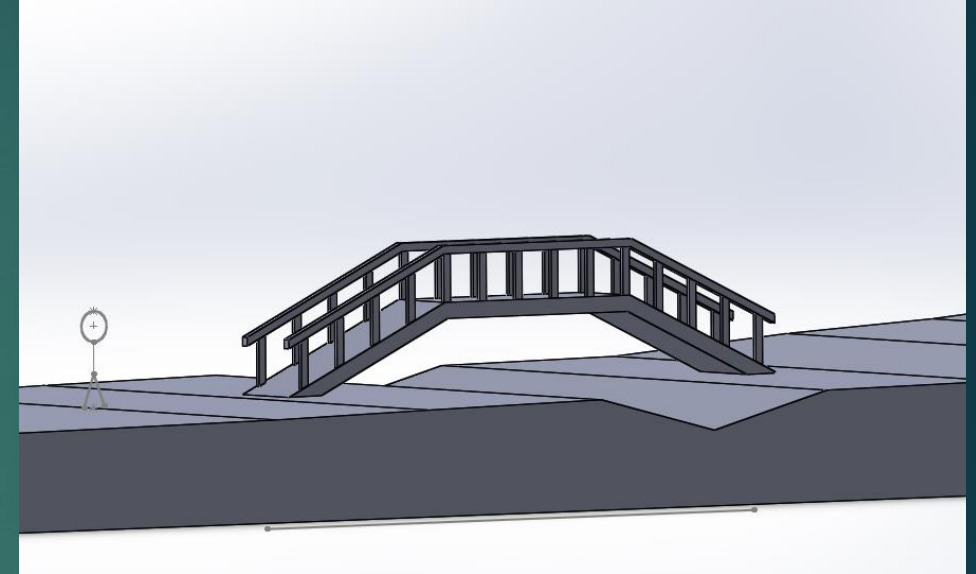
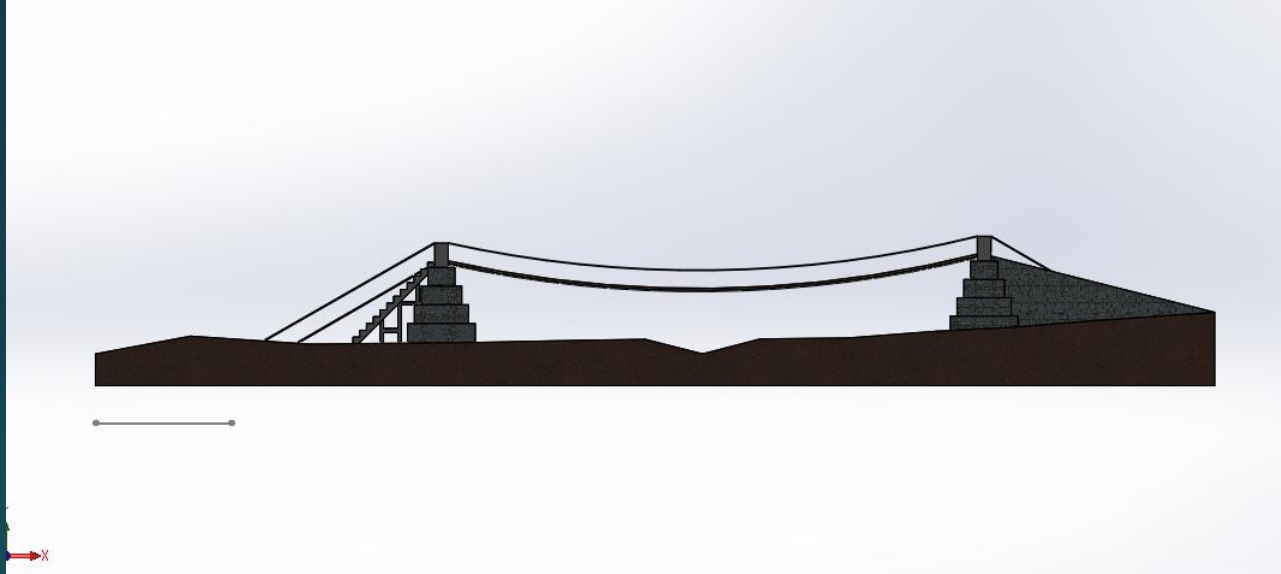

Selected Bridge Design

Our goal is to be able to build this bridge within a budget of \$15,000 after donated labor and materials.

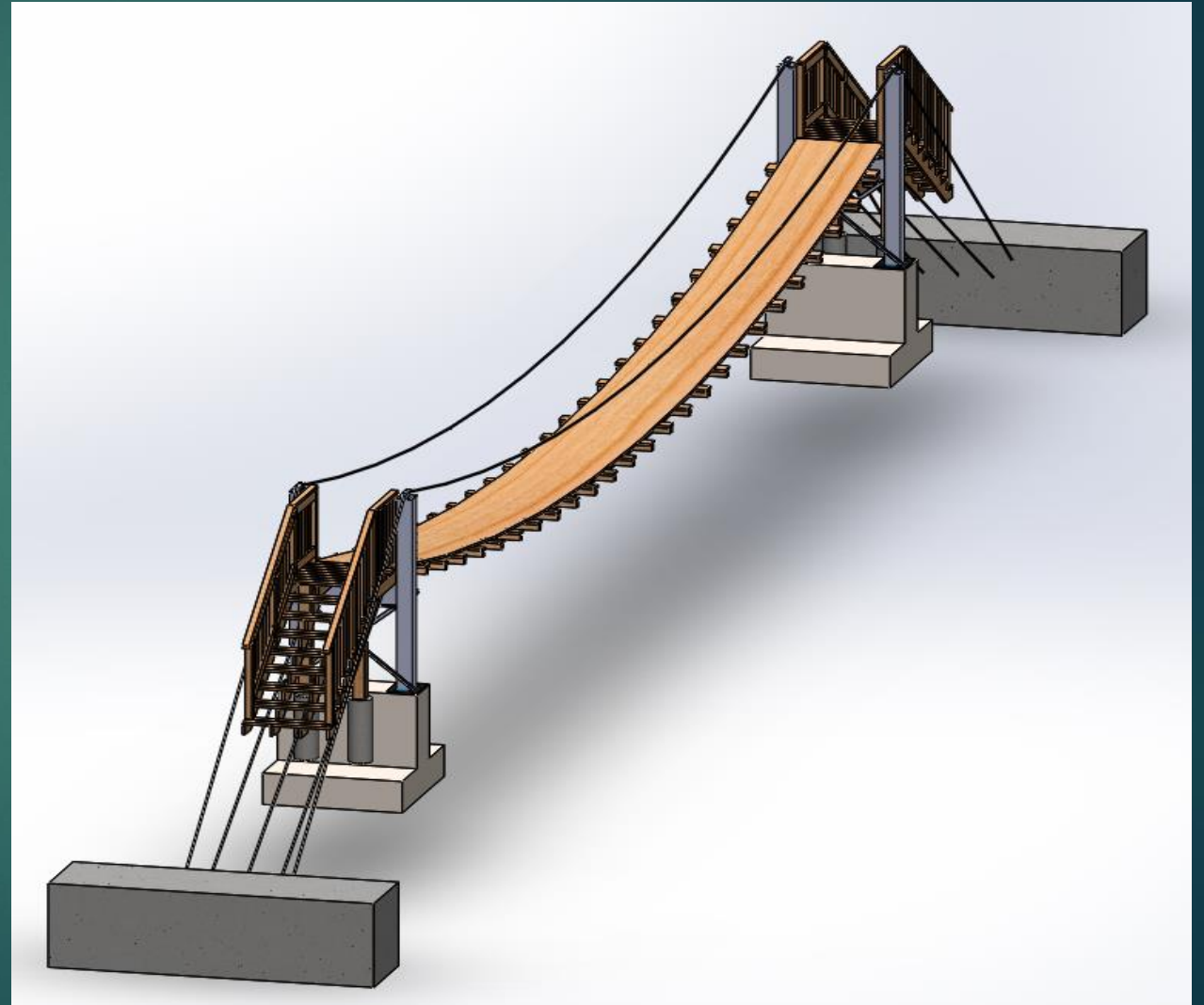

Profile View of the Bridge

BRIDGE IS SYMMETRICAL: ALL DIMENSIONS ARE MIRRORED FOR BOTH SIDES OF THE BRIDGE

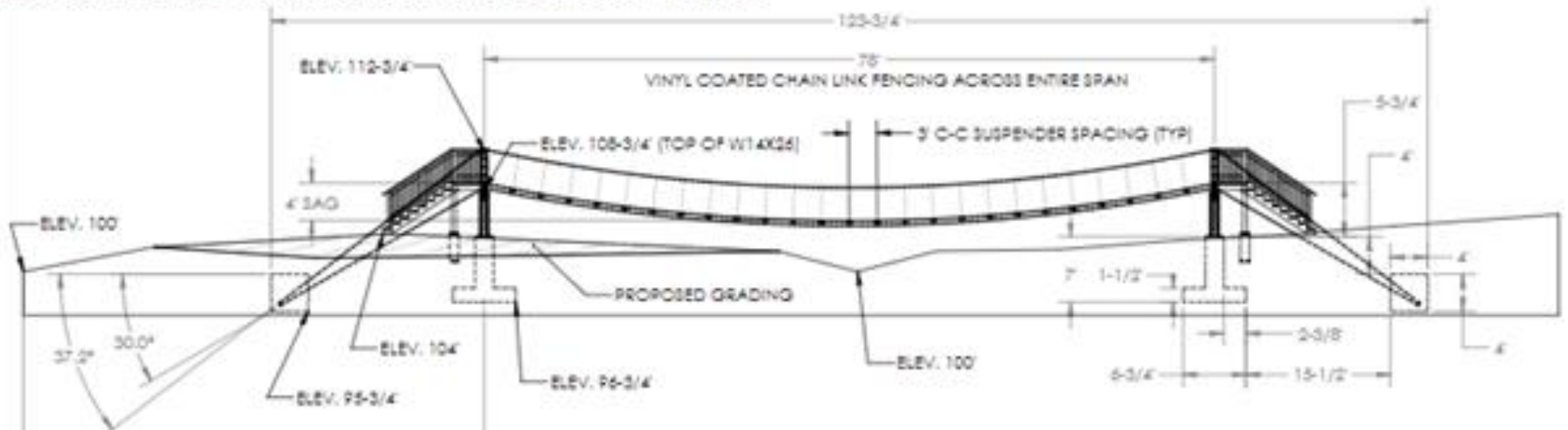

Decking and Cable Design

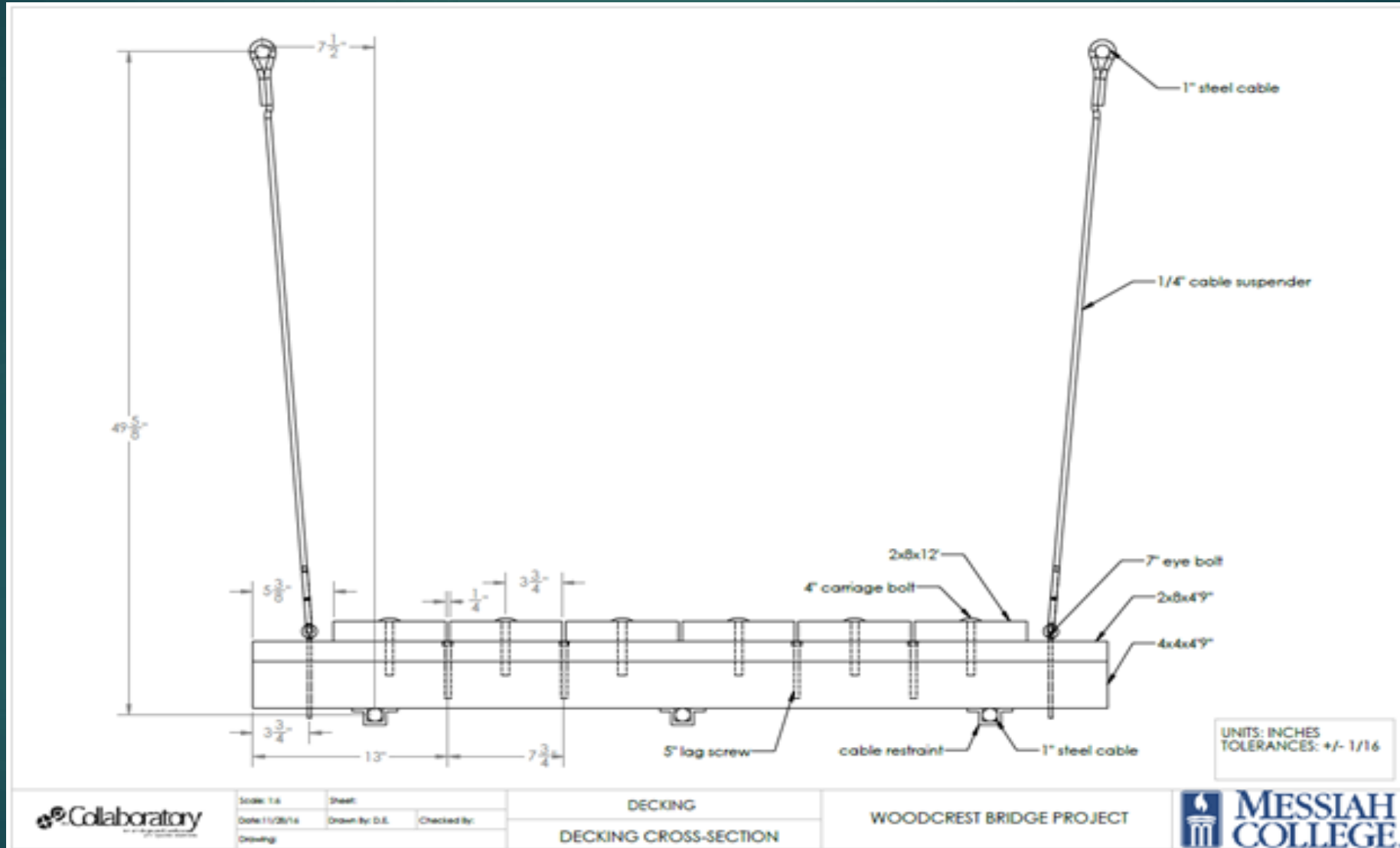

Foundation Design

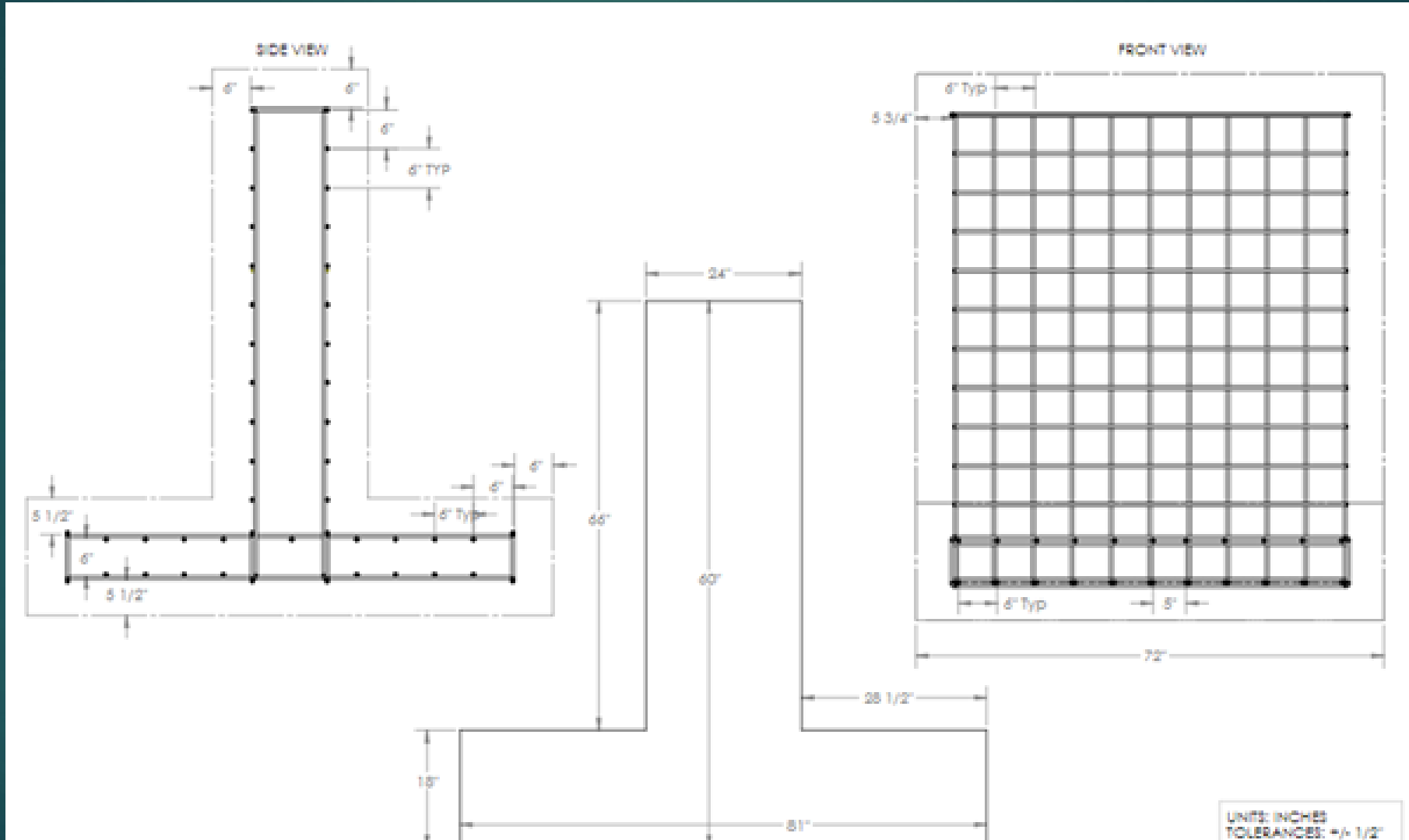

Anchor Design

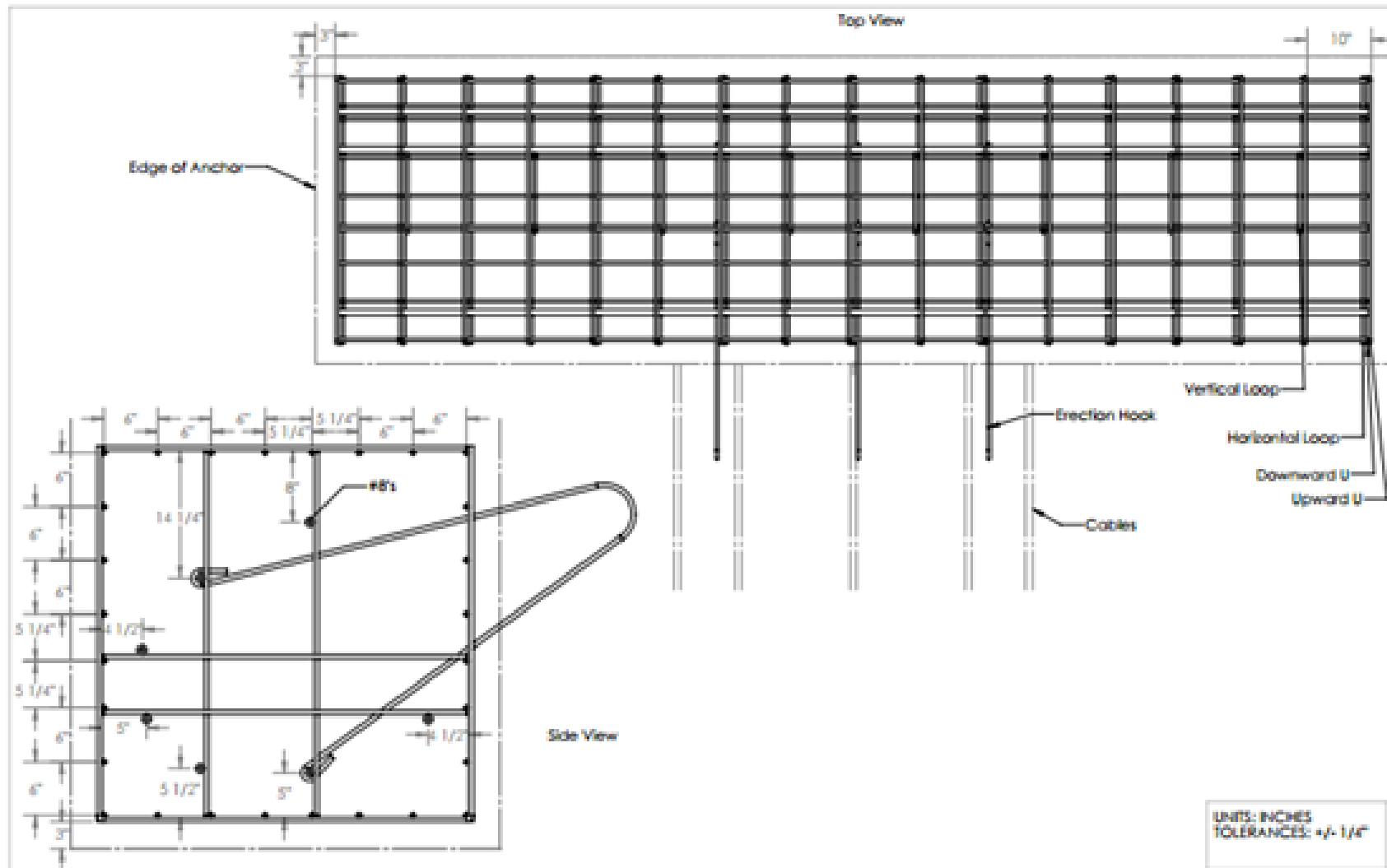

Tower Design

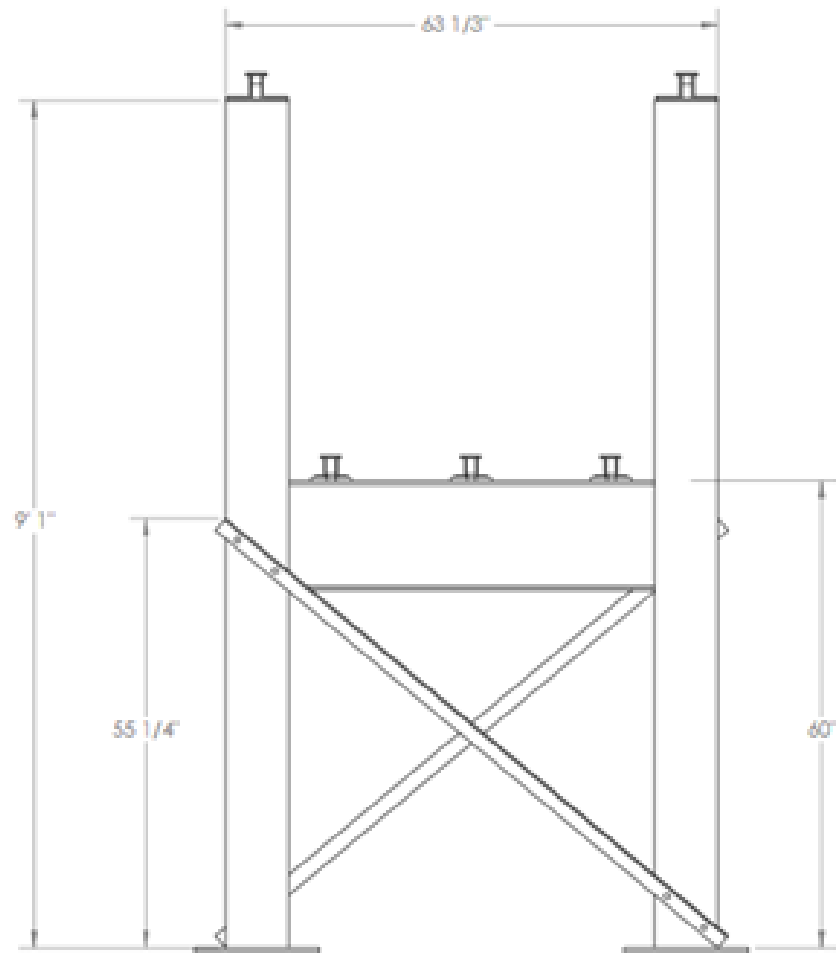

TOWER FRONT VIEW

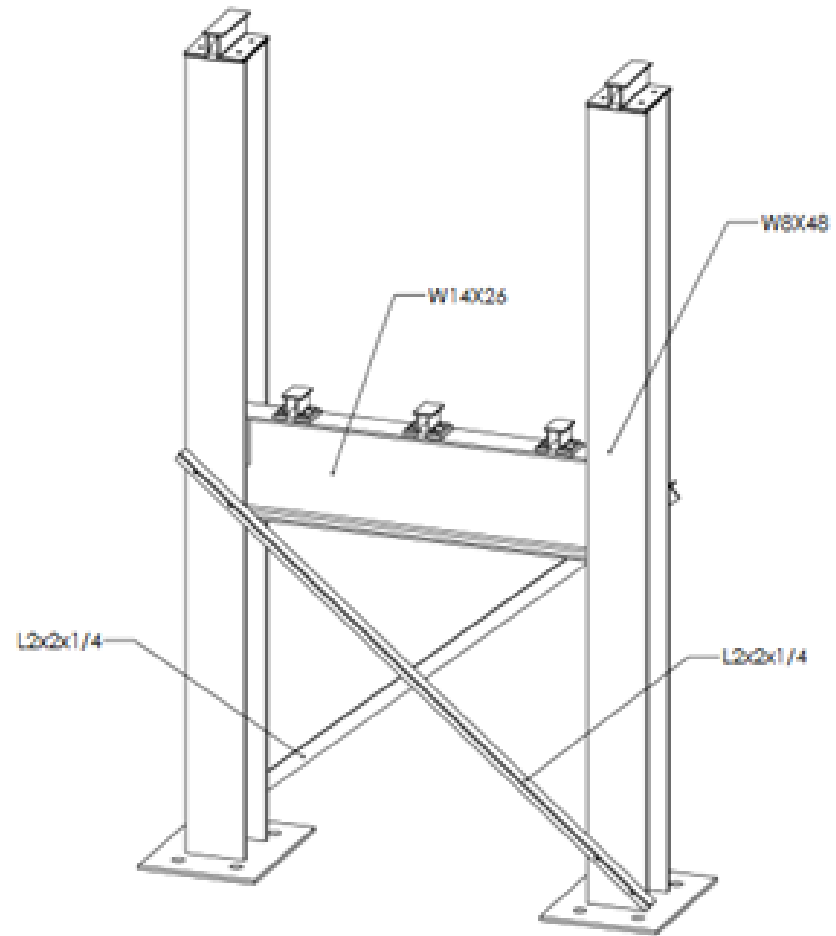

TOWER DIMETRIC VIEW

Stair Design

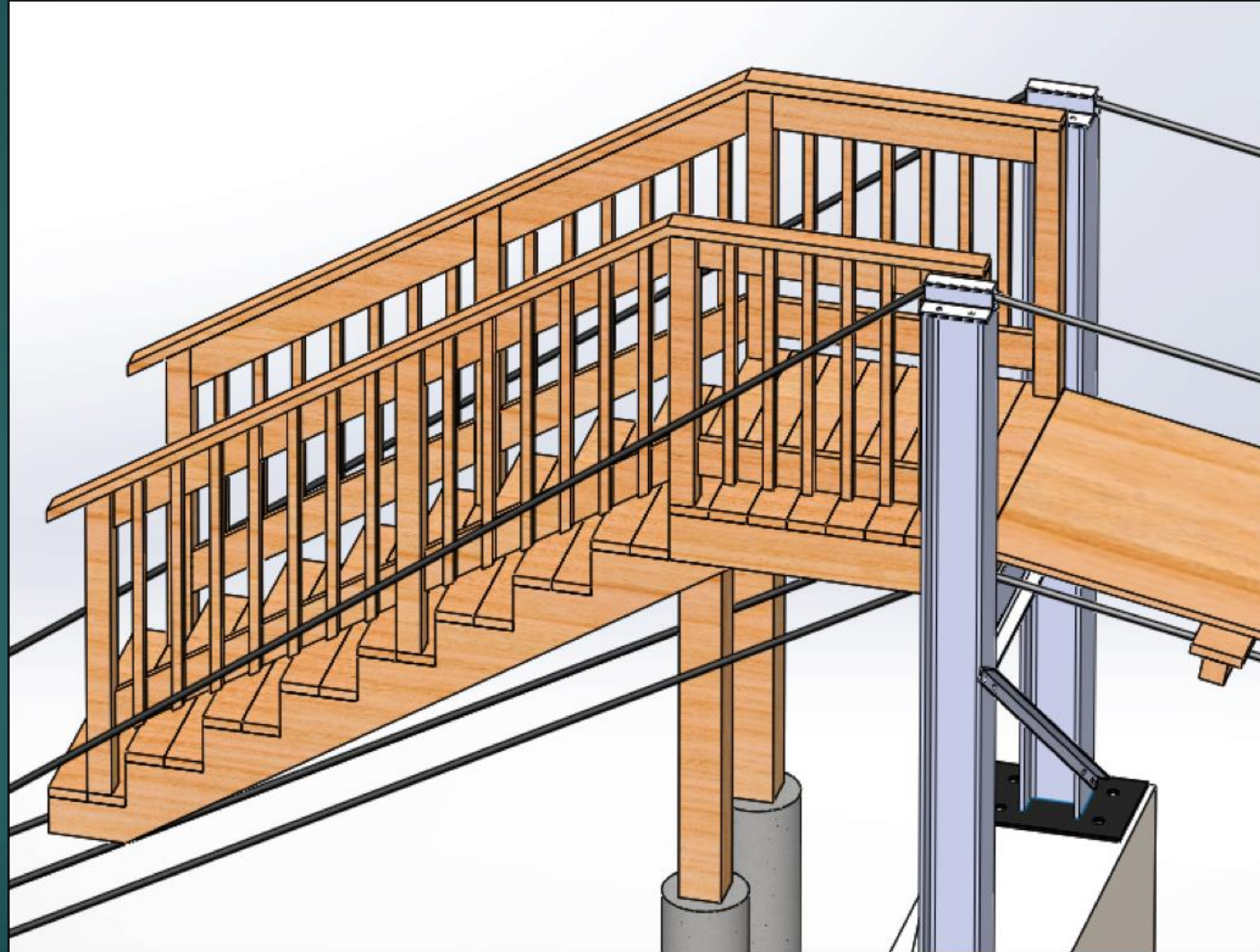

Conclusion / Future Plans

- Calculations and Design is in the process of being verified by Larson Design Group
- Documentation has been submitted to Larson Design Group to obtain permitting over the summer.
- Foundation work will begin in Fall of 2017

Acknowledgements

- Professor Heisey - For his support and guidance for our team.
- Dr. Swartz - For his involvement and bridge structure input for our team
- Larson Design Group - Mr. Quentin Rissler, PE, and Mr. Michael Kuhns, PE
For providing significant time and technical input to help improve our bridge design and to reach our goals.
- Tyler Miller- For assistance in design and calculations.
- Horst Construction - For assistance in construction estimating.

Questions?

